



# TBC CONSOLES

MODULAR Series

"SECURITY TWO"

Model: M-S2.af

Ideally suited for security monitoring or high end multimedia applications. The unique, cutting edge shape of the "SECURITY TWO" features an adjustable height countertop combined with TBC's adaptable aluminum frame system. **Base model** features include:

- adj. ht. desktop with hand crank (26" - 29")
- steel base ("alum" or matte black finish) with floor levelers.
- 2 bay angled turret @ 3 r.u. (6 r.u. total)
- aluminum frame system for unlimited monitor and speaker configurations
- includes 6 tilt/swivel LCD mounting brackets
- plastic laminate or linoleum finish with black bullnose bumper edging



(shown with **optional** articulating keyboard platform, 4 LCD nova articulating arms.)

base model: **\$3,715**

(shipping + handling additional)

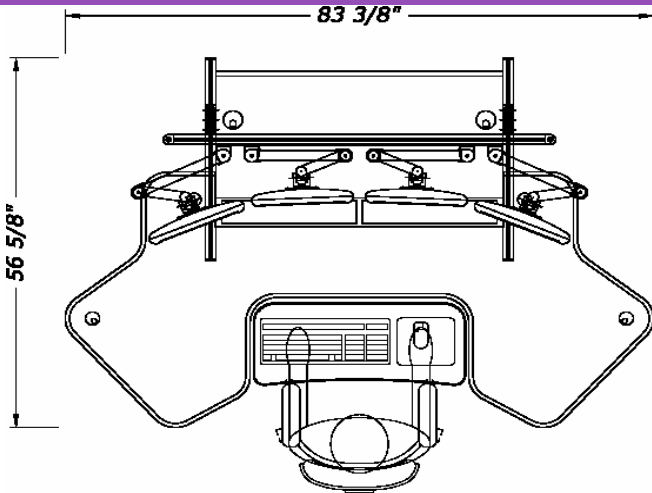

PLAN

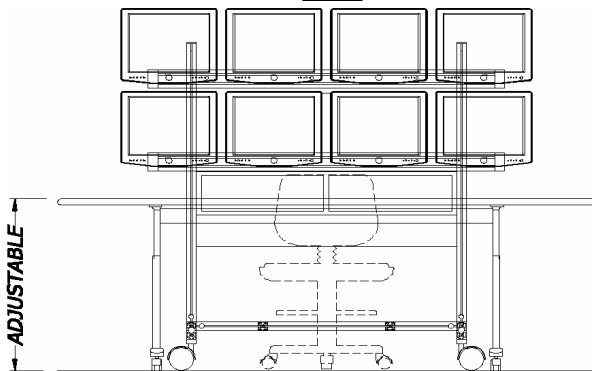

ELEVATION

## Optional Finishes

multi-ply wood edge with laminate top	\$ 345
multi-ply edge with real wood veneer top	630
solid MDF (1.125" thick) with clear lacquer	650
sanded Plexi-glas (1" thick)	1,220
solid wood (maple, oak, cherry, mahogany)	1,665

## Optional Accessories

"NOVA" articulating, piston-assist LCD arm	\$ 325
MBS-BKT tilt/swivel LCD mounting bracket	90
MBS-FA1 fixed LCD arm (w/tilt/swivel brkt.)	125
articulating keyboard/mouse platform	525
(4) casters on desktop steel frame base	40
equipment cart (mdl EC-1.5) w/tower cubby	835

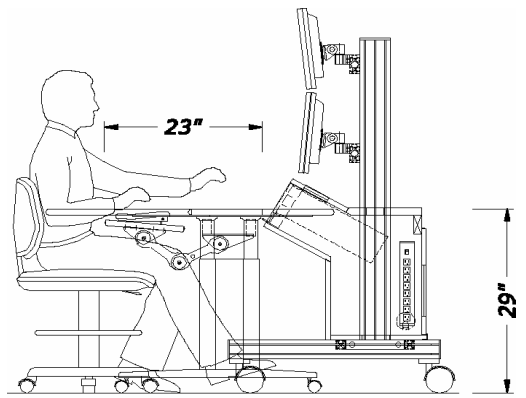

SECTION

TBC CONSOLES 115 Cabot Street West Babylon New York 11704  
 phone: (631)293-4068 fax: (631)293-4075 toll free: (888)CONSOLE  
 e-mail: tbc@TBCconsoles.com web site: www.TBCconsoles.com