

TBC CONSOLES

PRODUCTION Series

PS-1

Model: PS-1

Functional, Rack-Bay segmented components made for control room and broadcast environments with multi-users. TYPICAL APPLICATIONS: Production rooms, Broadcast Centers, Master control rooms, Edit Consoles and Monitor Walls

- base cabinet with 9 ru per bay (adjustable shelves are a no cost option)
- removable front vented access panels;
- front and rear rack rails; open back;
- upper rack turret with 10 ru @ 20 degrees;
- countertop (18"--28" d) in choice of laminate or linoleum finish; steel support arms
- black bumper or solid hardwood edge



(shown with **optional**, extension pods, solid wood end panels, corian countertop)

(weight: 225 lbs/bay.)

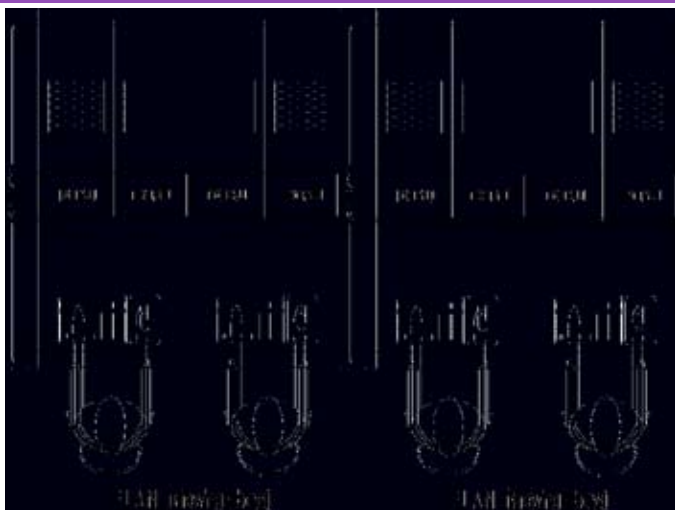

Optional Finishes per bay

multi-ply wood edge with laminate top	\$ 120
multi-ply edge with real wood veneer top	235
sanded Plexi-glas (1" thick)	435
solid wood (maple, oak, cherry, mahogany)	425
solid surface (eg. Corian)	690

Optional Accessories

extension pod for phone, data jack, etc.	\$ 485
upper rack storage module with 12 ru	335
oak, cherry or mahogany end panel	680
rear vented, removable access doors	145
slide-out keyboard/mousepad platform	435
countertop cutout with component wedge	375

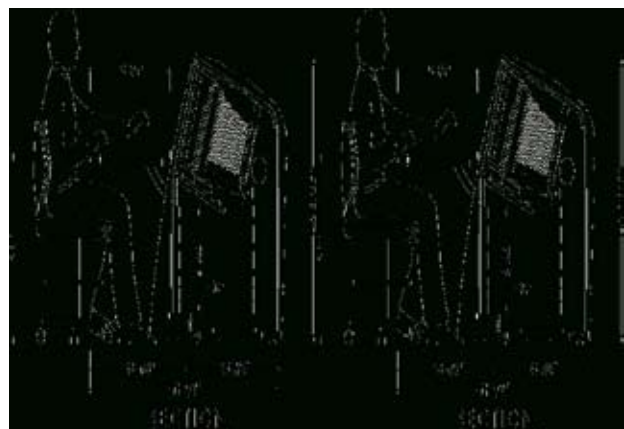
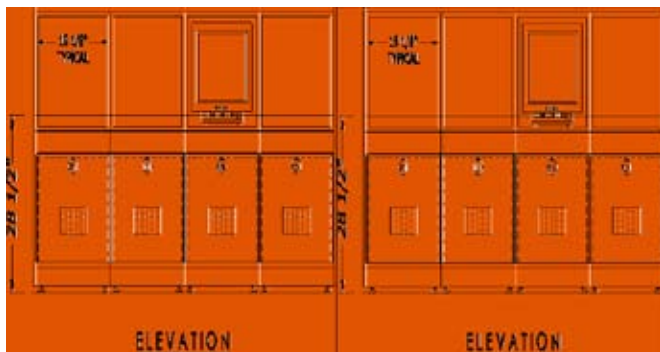

TBC CONSOLES 170 Rodeo Drive Edgewood New York 11717
 phone: (631)293-4068 fax: (631)293-4075 toll free: (888)CONSOLE

rev. 10/06

e-mail: tbc@tbconsoles.com

web site: www.tbconsoles.com