

**Functional, Rack-Bay segmented components made for control room and broadcast environments with multi-users. TYPICAL APPLICATIONS: Production rooms, Broadcast Centers, Master control rooms, Edit Consoles and Monitor Walls**

- base cabinet with 9 ru per bay (adjustable shelves are a no cost option)
- removable front vented access panels;
- front and rear rack rails; open back;
- rear monitor ledge for 1 x 20" monitor;
- countertop (18"--28" d), steel support arms in choice of laminate or linoleum finish
- black bumper or solid hardwood edge



(shown with **optional**, upper rack storage modules)

(weight: 225 lbs/bay.)

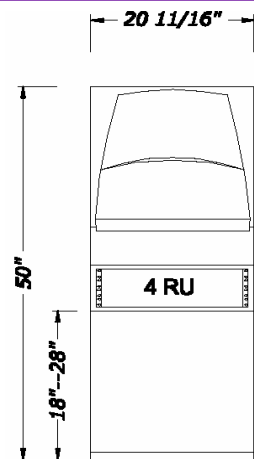

**PLAN VIEW**

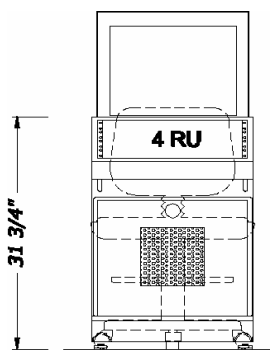

**ELEVATION**

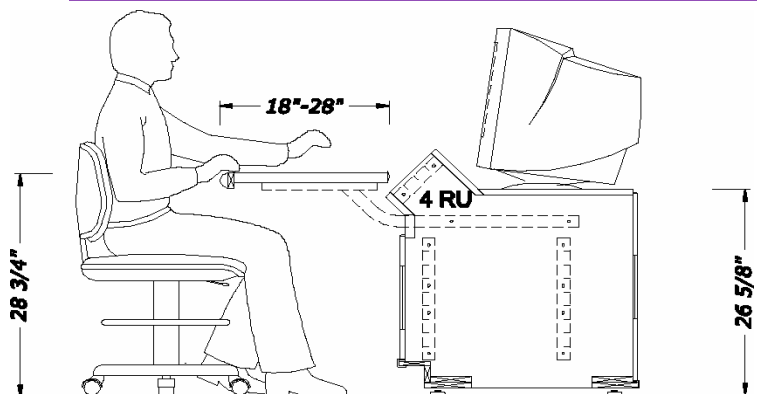

**SECTION**

**Optional Finishes per bay**

- sanded Plexi-glas (1" thick)
- solid surface (eg. Corian)

**Optional Accessories**

- monitor riser with ribbed rubber surface
- upper rack storage module with 12 ru
- oak, cherry or mahogany end panel
- rear vented, removable access doors
- slide-out keyboard/mousepad platform
- countertop cutout with component wedge